

LUXMAN

OWNER'S MANUAL

R-113

AM/FM Stereo Receiver

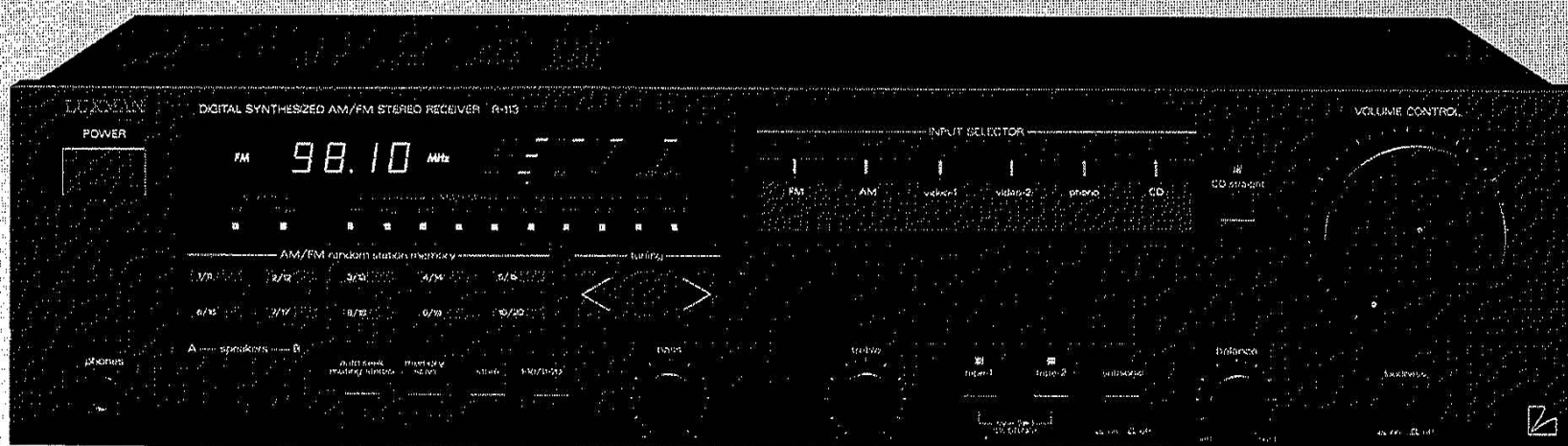

TABLE OF CONTENTS

Introduction	4
Special Features	5
Controls, Switches, Jacks & Terminals	6, 7, 8, 9
Connection Diagram	10
Connection Guidelines	11, 12
Operation Guidelines	13, 14
Care & Maintenance	15
Block Diagram	15
In Case Of Difficulty	16
Specifications	17

WARNING: To reduce the risk of fire or electric shock, do not expose this appliance to rain or moisture.

CAUTION: To prevent electric shock, do not use this (polarized) plug with an extension cord, receptacle or other outlet unless the blades can be fully inserted to prevent blade exposure.

INTRODUCTION

WELCOME!

Luxman welcomes you to the growing number of discerning audiophiles who own and operate Luxman Audio and Audio-Video Products. We take great pride in the long tradition of excellence in sonic quality that the Luxman name represents. This manual has been prepared to help you maximize your enjoyment of the outstanding performance and features of your new Luxman R-113.

This AM/FM stereo receiver incorporates the latest in high technology features, such as auto seek tuning, 20 random access station memories, CD straight, pre-out jacks, signal processor jacks, and two high level inputs for the connection of the stereo audio outputs of A/V sources.

To realize the exceptional performance for which this receiver is capable, it is necessary that all signal sources and speaker systems used with it are of the highest sonic quality. We recommend complementary Luxman components wherever possible.

Please study this manual carefully and become acquainted with all the special features, operation and capabilities of your new Luxman R-113. Should you have any questions, or desire information on other Luxman products, please contact your local Luxman dealer.

WHEN YOU OPEN THE BOX

Before any Luxman product leaves the factory it is carefully inspected for physical imperfections as a routine part of Luxman's systematic quality control. This, along with full electrical testing, should insure quality craftsmanship and performance. After you have unpacked the unit, inspect it for any physical damage. Save the shipping carton and all packing materials, as they are essential to reduce to a minimum the possibility of transportation damage, should the product ever need to be shipped again. In the unlikely event that damage has occurred, notify your dealer immediately and request the name of the carrier so that a written claim to cover shipping damages can be initiated.

THE RIGHT TO ANY CLAIM AGAINST A PUBLIC CARRIER CAN BE FORFEITED IF THE CARRIER IS NOT NOTIFIED PROMPTLY AND IF THE SHIPPING CARTON AND PACKING MATERIAL ARE NOT AVAILABLE FOR INSPECTION. SAVE ALL PACKING MATERIALS UNTIL THE CLAIM HAS BEEN SETTLED.

INSTALLATION AND PLACEMENT

Because some heat is generated by the R-113, adequate air circulation must be provided to maintain cool operation. Leave adequate space around the receiver (at least 3 inches on the top and 1 inch on the sides and rear) for proper air circulation. Also, the Luxman R-113 should not be completely enclosed with other heat producing components. If the Luxman R-113 is going to be mounted in an enclosed cabinet, it is recommended that the back of the cabinet have vents to allow air to circulate around the amplifier. With these considerations implemented, the Luxman R-113 should provide exceptional performance in any reasonable environment.

Of course, such normal considerations as protection from excessive dust and moisture should always be observed. The Luxman R-113 receiver has been carefully designed with high quality components so that long term undiminished performance may be expected when it is operated in accordance with the instructions provided.

SPECIAL FEATURES

CD STRAIGHT

Direct connection from the CD input terminals to the volume control is provided to bypass the input selector, tape monitor, signal processor, sub-sonic filter, balance control and loudness circuit.

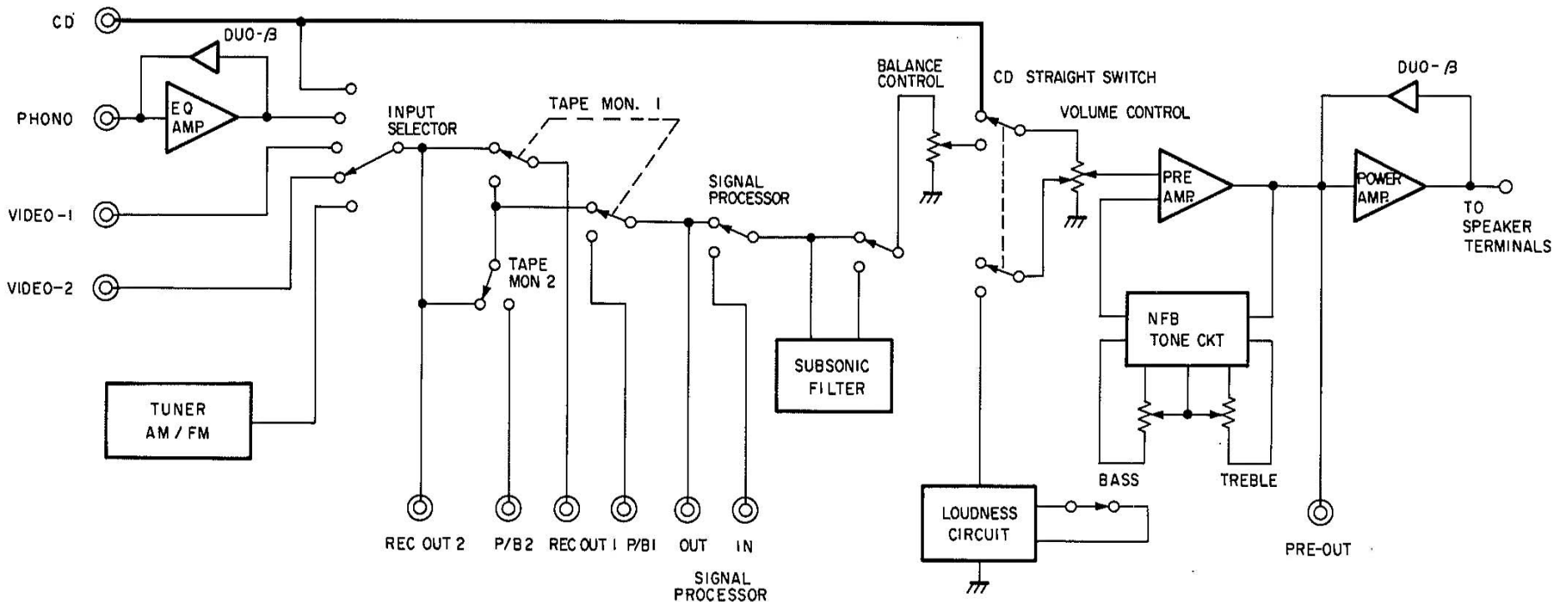

By bypassing these functions, the shortest direct path to the power amplifier is thus achieved, ensuring the best accuracy, imaging and impact.

NOTE: BE SURE CD STRAIGHT BUTTON IS IN THE **OUT** POSITION (CD STRAIGHT INDICATOR **OFF**) WHEN USING SOURCES OTHER THAN CD.

PRE-OUT JACKS

These jacks permit the connection of additional out-board power amplifiers to drive additional speakers and/or for multiple room sound system applications.

SIGNAL PROCESSOR JACKS & SWITCH

This allows the connection of an equalizer (G-100), a system remote control center (U-100) or other desired signal processor without having to give up a tape jack facility.

TOROIDAL POWER TRANSFORMER

This special high efficiency transformer, coupled with high energy storage capacitors, provides the dynamic and steady state reserves necessary for the most demanding music transients.

20 AM/FM RANDOM STATION MEMORY

A total of 20 stations can be stored in any random combination of AM or FM stations. They can then be instantly recalled for immediate listening, without the necessity of tedious tuning.

25 kHz MANUAL/50 kHz AUTO FINE TUNING CAPABILITY

Some cable distribution systems shift the original FM station frequencies by 25 or 50 kHz increments for interference reduction, etc. A switch, accessed through a small slot under the unit, allows the R-113 to be precision tuned to the exact frequencies of these cable stations.

CONTROLS, SWITCHES, JACKS & TERMINALS

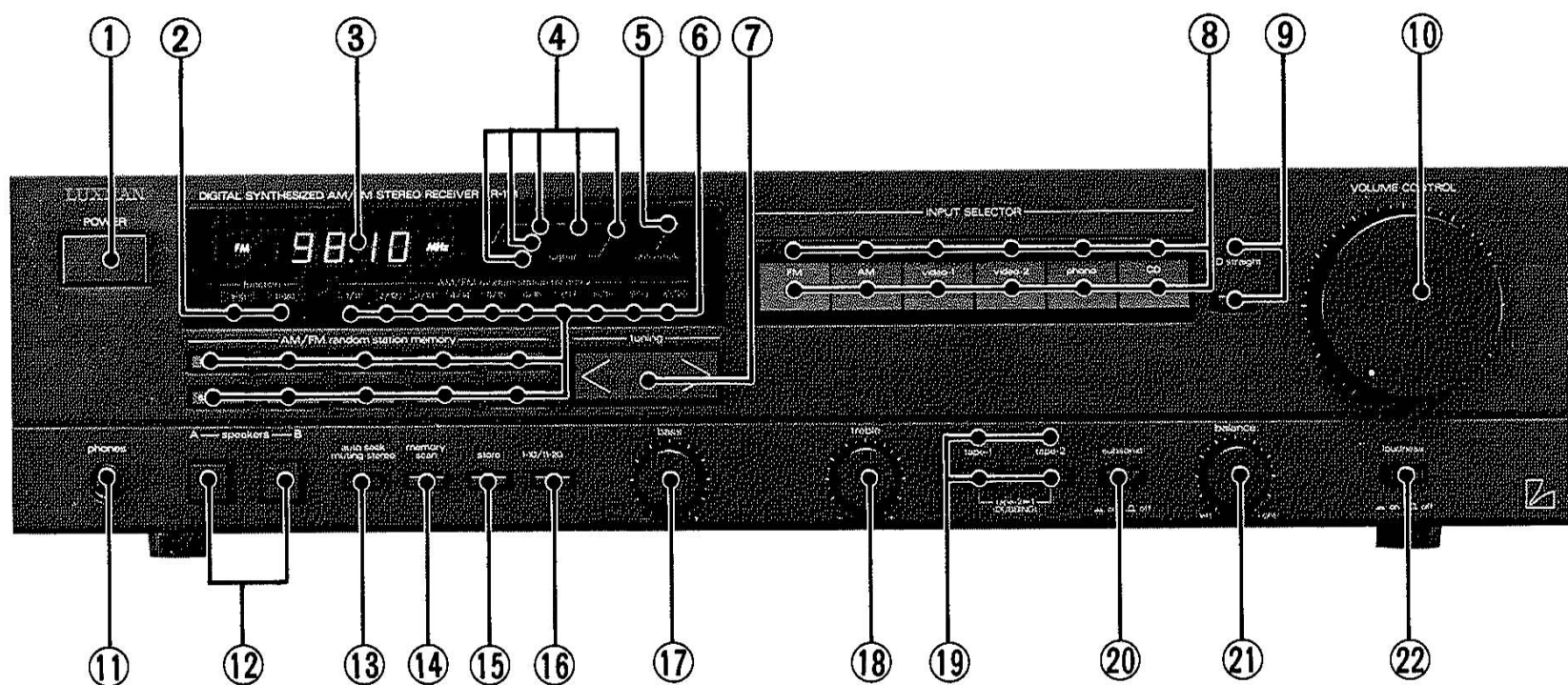

● FRONT PANEL

1. POWER BUTTON

Pressing this button turns the unit on, along with other equipment that may be plugged into the rear panel switched AC outlets.

2. FUNCTION Indicators

These show which set of memory presets are in use and are activated by the 1 — 10/11 — 20 button (see item #16).

3. DIGITAL DISPLAY

This display window shows the frequency of tuned AM and FM stations. In addition, an FM stereo indicator and memo (memory) display (see item #15) are included.

4. SIGNAL STRENGTH Indicator

Five LED indicators will light upward and to the right with increasing strength of AM or FM stations tuned.

5. AUTO SEEK Indicator

Will light up to show that AUTO SEEK mode has been selected (see item #13).

6. AM/FM RANDOM STATION MEMORY Buttons and Indicators

A total of 20 AM and/or FM stations may be placed into memory in any random order and recalled for instant play, with these buttons. They work in con-

junction with the STORE (item #15) and 1 — 10/11 — 20 (item #16) buttons. An indicator will light up for each memory preset selected.

7. TUNING Button

Allows manual up/down tuning and initiates auto tuning in the AUTO SEEK mode. See item #13.

8. INPUT SELECTOR/Indicators

Press one of these buttons to select any one of six sources: FM, AM, VIDEO-1, VIDEO-2, PHONO and CD. A corresponding indicator will light up when a button is pressed.

9. CD STRAIGHT Button/Indicator

For optimum sound quality in CD operation, press this button to bypass the balance control and other switching functions. See SPECIAL FEATURES section, page 5, for further details.

NOTE: BE SURE CD STRAIGHT BUTTON IS IN THE OUT POSITION (CD STRAIGHT INDICATOR OFF) WHEN USING SOURCES OTHER THAN CD.

10. VOLUME CONTROL

Allows precision, low noise adjustment of volume level. It is recommended that the volume control be set to a low position prior to power turn on and when switching between sources.

CONTROLS, SWITCHES, JACKS & TERMINALS

11. PHONES JACK

Connection of stereophonic headphones to this jack allows private listening. There is signal at the jack at all times. Placing the speaker A and B buttons (item #12) in the OUT position, will allow private listening.

12. SPEAKERS A and B Buttons

Two sets of stereo speaker systems may be used with the R-113; A and B buttons corresponding with A and B speaker terminals on the back panel (item #29). You may choose independent or simultaneous operation of the two systems by using these buttons.

NOTE: The impedance of each speaker system should equal or exceed 16 ohms when driving two sets at the same time.

13. AUTO SEEK/MUTING STEREO Button

When depressed, this button activates the AUTO SEEK automatic tuning mode, in conjunction with the TUNING button (item #7), for both AM and FM operation. In addition, weak FM stations will be muted and the unit will be placed in the FM STEREO mode.

The AUTO SEEK indicator (item #5) will light and the STEREO indicator (item #3) will also light if tuned to an FM stereo station.

When depressed a 2nd time (AUTO SEEK indicator OFF), manual tuning is activated, muting is removed, and the receiver is returned to MONO operation.

14. MEMORY SCAN

When depressed, each station in memory will be scanned for a 5 second interval. To defeat, press any tuner function other than memory scan.

15. STORE Button

Depressing this button will allow any tuned FM or AM station to be stored in any one of the 20 AM/FM RANDOM STATION MEMORY locations (see also item #6). The MEMO indicator will light when STORE is depressed.

16. 1 — 10/11 — 20 Button

Selects between two sets of 10 station memories provided by the dual function AM/FM RANDOM STATION MEMORY buttons. Selection of stations 1 through 10 or 11 through 20 are shown by the FUNCTION indicators (item #2).

17. BASS CONTROL

This control will increase or decrease low frequency content in the program material. In the center detent position, a flat frequency response results.

18. TREBLE CONTROL

This control will increase or decrease high frequency content in the program material. At the center detent position, a flat frequency response results.

19. TAPE-1/TAPE-2/TAPE 2 ▶ 1 (DUBBING) Buttons/Indicators

For selection of connected tape decks 1 or 2 for monitoring or playback operations. In addition, when both are depressed, tape copying (dubbing) from deck 2 to deck 1 is possible.

20. SUBSONIC Button

When depressed, a subsonic filter suppresses very low frequency rumble, below the audible range, to prevent excessive woofer cone excursions and distortion.

21. BALANCE CONTROL

Adjust for unequal volume level between channels. Normally, with today's high quality sources, it is seldom necessary to move this control from its precision center detent position.

22. LOUDNESS Button

Depressing this button introduces a moderate boost of the very low and high frequencies when the volume control is set below the half-way position. This compensates for the human ear's characteristic at low listening levels.

CONTROLS, SWITCHES, JACKS & TERMINALS

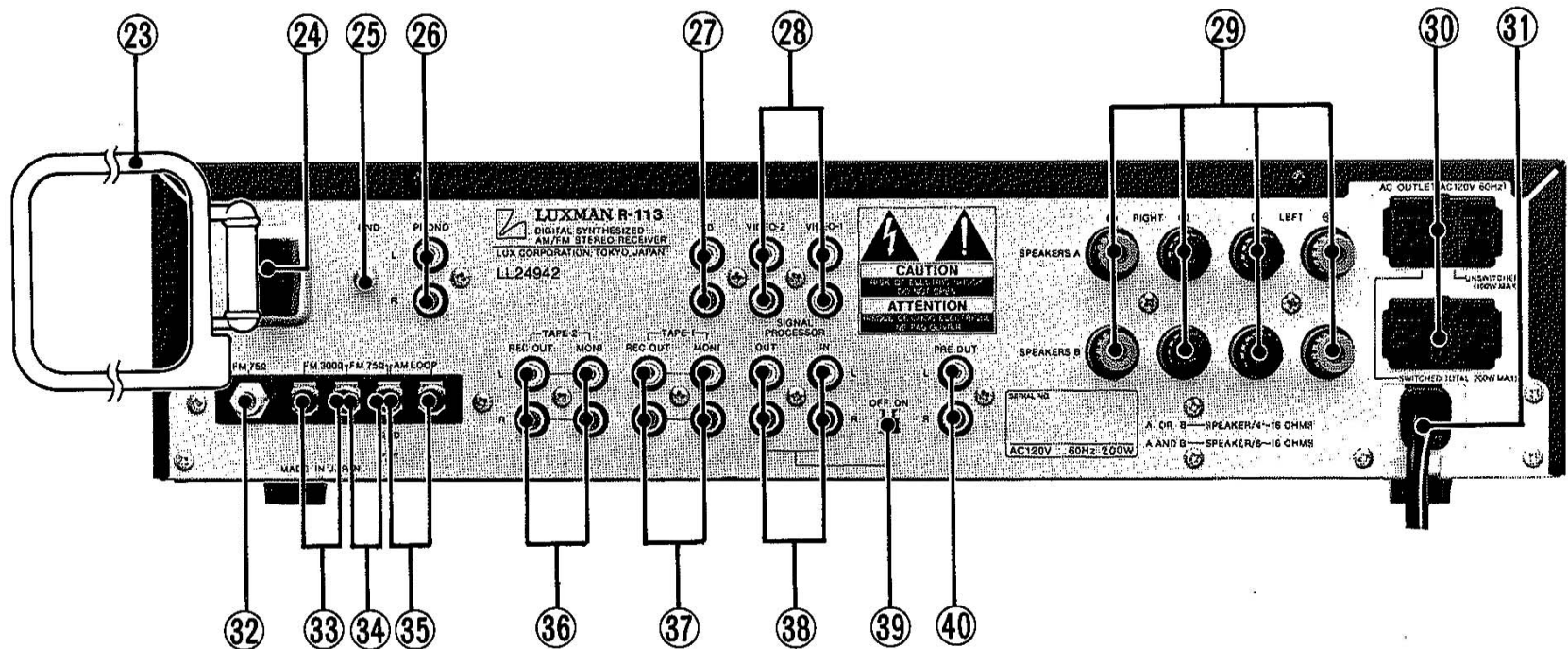

● REAR PANEL

23. AM LOOP ANTENNA

This antenna can be rotated on its holder (item #24) for maximum pick-up, or removed and placed elsewhere for best reception (within the limitation of its 23" lead length).

24. HOLDER-AM ANTENNA

This holder is designed for easy mounting or removal of the AM LOOP ANTENNA. Align mating surfaces carefully and install with a firm push.

25. GND TERMINAL

Connect the common (ground) lead of your record player to this terminal.

26. PHONO JACKS

A moving magnet (MM) type cartridge may be connected to these inputs.

27. CD JACKS

This set of jacks are for connection of a compact disc (CD) player. They may also be used for any other high level signal source.

28. VIDEO-1, VIDEO-2 JACKS

These input jacks allow the audio outputs of two video sources (VCR's, LD's, etc.) to be played through the R-113. They may also be used for any other high level signal source.

29. SPEAKER TERMINALS

You may connect 2 pairs of stereo speaker systems to these terminals, one pair to the upper "A" terminals and a 2nd pair to the lower "B" terminals.

When connecting, be sure to observe correct PHASING by connecting of the RED (+) and the BLACK (—) terminals of the R-113 to the corresponding RED (+) and BLACK (—) terminals of your speakers on each channel.

The speaker systems may be switched on and off by the front panel A and B SPEAKER buttons (item #12).

CONTROLS, SWITCHES, JACKS & TERMINALS

30. AC OUTLETS

For convenient AC power connection of other audio and video components in your system, 3 SWITCHED outlets (200 Watts max.) and 1 UNSWITCHED outlets (100 Watts max.) are available. The "w" mark on the lower side of each outlet indicates the ground side of the polarized AC line.

31. AC POWER CORD

Insert the polarized plug of the R-113 into any 120 Volt AC, 60 Hz wall outlet. The white lined side of the cord is the ground side.

32. 75Ω FM ANT. "F" CONNECTOR

For connection of 75 Ohm co-ax cable lead-in with "F" connector.

33. 300Ω FM ANT. TERMINALS

For connection of 300 Ohm "twin lead" type antenna lead-ins.

34. 75Ω FM ANT. TERMINALS

For direct wire connection of 75 Ohm co-ax cable lead-ins or for connection of the T-type di-pole antenna supplied with the R-113.

35. AM LOOP ANT. TERMINALS

For connection of the leads of the AM LOOP ANTENNA (item #23) supplied with the R-113.

36. TAPE-2 REC OUT AND MONI JACKS

Connect a 2nd tape deck to these jacks in the same manner as item #37 below.

37. TAPE-1 REC OUT AND MONI JACKS

Connect the LINE IN and LINE OUT jacks of your audio tape deck to these REC OUT and MONI (monitor) jacks respectively.

38. SIGNAL PROCESSOR IN AND OUT JACKS

For connection of an equalizer (G-100), System remote control center (U-100) or other signal processor as desired. They are switched in or out by the rear panel OFF-ON switch (item #39).

39. OFF-ON signal processor switch

When switched to the ON position, an equalizer or other signal processor connected to the rear panel SIGNAL PROCESSOR jacks (item #38) will be placed in the signal path.

NOTE: Be sure to always leave this switch in the OFF position if a signal processor is not connected.

40. PRE-OUT JACKS

For connection of external power amplifiers for multi-speaker or multi-room applications.

NOTE: See CONNECTION DIAGRAM, page 10, for typical connections to all jacks and terminals (items 23 through 40).

CONNECTION DIAGRAM

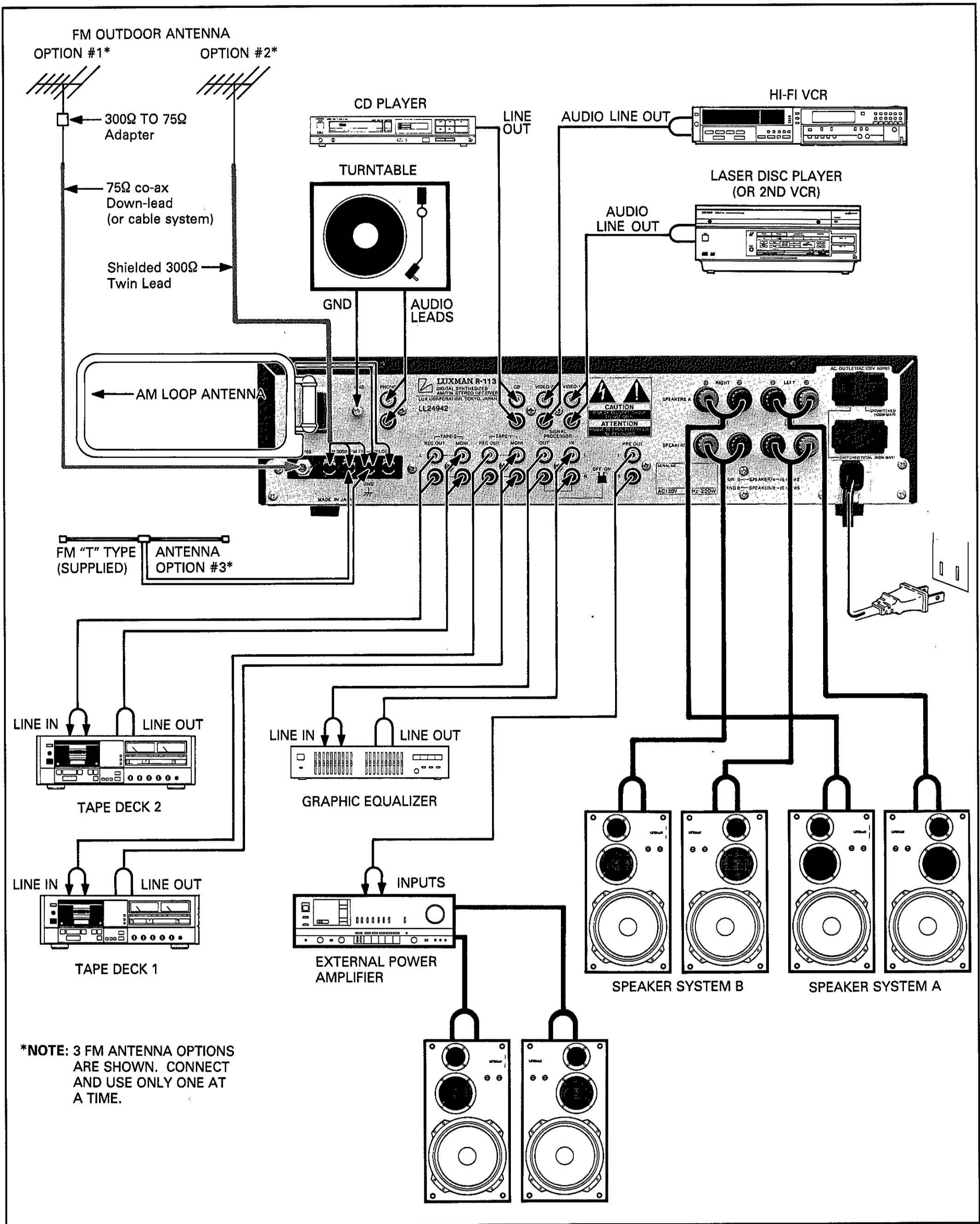

CONNECTION GUIDELINES

BEFORE MAKING CONNECTIONS

It is always wise to ensure that all AC line cords of the various components that you are interconnecting are unplugged from the wall outlets during the hook-up process. This will prevent any inadvertent damage to your speakers or receiver from incorrect control settings or connections.

INTERCONNECTING LEADS (Patch Cords)

Be sure that left and right channel identification is correct when making interconnections. Most patch cords are color coded with RED ends for the right channel and BLACK or WHITE ends for the left channel, to make this job easier.

In addition, all jacks on the rear of the R-113 have red centers for right channel and white for left channel.

CONNECTING THE RECORD PLAYER (TURNTABLE)

In addition to the audio lead connections, be sure to always connect the ground lead from the player to the GND terminal (item #25) on the R-113.

CONNECTION OF TAPE DECKS

One of the common problems in connecting tape decks is confusing the LINE IN and LINE OUT connections to the receiver, resulting in no output even in the SOURCE modes. To prevent this, always connect the LINE OUT jacks of the deck to the MONI (monitor) input jacks of the receiver and connect the LINE IN jacks of the deck to the REC OUT (record out) jacks on the receiver.

CONNECTION TO PRE-OUT JACKS

When you connect an external amplifier to these jacks, the internal amplifier of the R-113 continues to function. If you wish to defeat the internal amp, simply place the SPEAKER A/B buttons (item #12) in the OUT position.

SPEAKER CONNECTIONS

The following items should be observed carefully when connecting your speakers:

1. Be sure PHASING is correct by connecting the RED (+) and the BLACK (—) terminals of the R-113 to the connecting RED (+) and BLACK (—) terminals of your speakers on each channel. Failure to do so will result in drastically reduced bass response and unstable, irregular stereo imaging.
2. To prevent the possibility of shorts, strip back the ends of the speaker leads about 1/2 inch and carefully twist the strands together. Loosen the speaker terminal knob by rotating it counter-clockwise. Insert the twisted end and turn clockwise to tighten.

Inspect carefully to ensure that no frayed strands exist that may short against the metal backpanel.
3. It is recommended that 16 AWG gauge wire, or larger, be used to prevent losses. You may wish to consider some of the commercially available speaker cables that are specifically designed to improve the amplifier to speaker interface.

SIGNAL PROCESSOR CONNECTIONS

Like tape decks, most of these types of equipment have LINE IN and LINE OUT jack identifications. Be sure LINE IN and LINE OUT jacks of the signal processor are connected to the R-113 SIGNAL PROCESSOR OUT and IN jacks respectively.

AC OUTLET CONNECTIONS

These outlets, item 30, may be used for power connection of most of the equipment used with your R-113. In general, connect your CD player and Graphic Equalizer to the SWITCHED outlets. Connect your Record Player (turntable), Cassette Deck, etc. to the UNSWITCHED outlets.

CAUTION: When connecting equipment to these outlets, be sure not to exceed their maximum power ratings of 100 Watts for the UNSWITCHED outlet and 200 Watts for the SWITCHED outlets.

CONNECTION GUIDELINES

AM ANTENNA

An AM LOOP ANTENNA comes packed with your R-113. Carefully unwrap and mount to back panel and connect leads referring to item #23 on page 8 and CONNECTION DIAGRAM, page 10.

FM ANTENNA CONNECTIONS

Included also with your R-113, is a T-type di-pole FM antenna. This type of antenna is simple and practical and will give adequate results in primary signal areas. To use it, unfold it into a "T" shape and connect its leads to the terminals marked "75Ω" on the back of the receiver (See page 10). The antenna is designed to operate in a horizontal position, and may be attached to a nearby wall.

As shown on page 10, the R-113 is also capable of accommodating other types of cable, including 75 Ohm coaxial cable (with or without "F" connector), and 300 Ohm shielded transmission line. These types of cable are for use with outdoor antennas, which will be discussed next.

OUTDOOR FM ANTENNA

As stated before, the supplied folded dipole antenna will give satisfactory results in primary signal areas. However, if you are located in a fringe area where signals are weak, then an outdoor antenna will be necessary. Even if you live in a strong signal location, an outdoor directional antenna may be needed to eliminate "multipath" reflections.

Multipath reflections are responsible for much of the distortion and noise associated with poor FM reception. They occur when radio waves from the transmitter bounce off of nearby mountains and tall buildings. The reflected waves follow different, more roundabout paths to your tuner and arrive slightly delayed and out of phase with the direct signal (hence, the term "multipath"). This causes distortion in the same manner that "ghost" images are generated on television.

The way to minimize multipath is to use a "beam type" antenna that can be aimed toward the FM transmitter and away from the multipath reflections. The best types of antennas to use are either a "Yagi" or "Log-Periodic" configuration with six or more elements designed expressly for FM reception.

If you want to receive stations from more than one general direction, then you will need a good quality antenna rotor system. This will enable you to point the antenna in the direction giving the least multipath interference, by means of a control box located near the receiver.

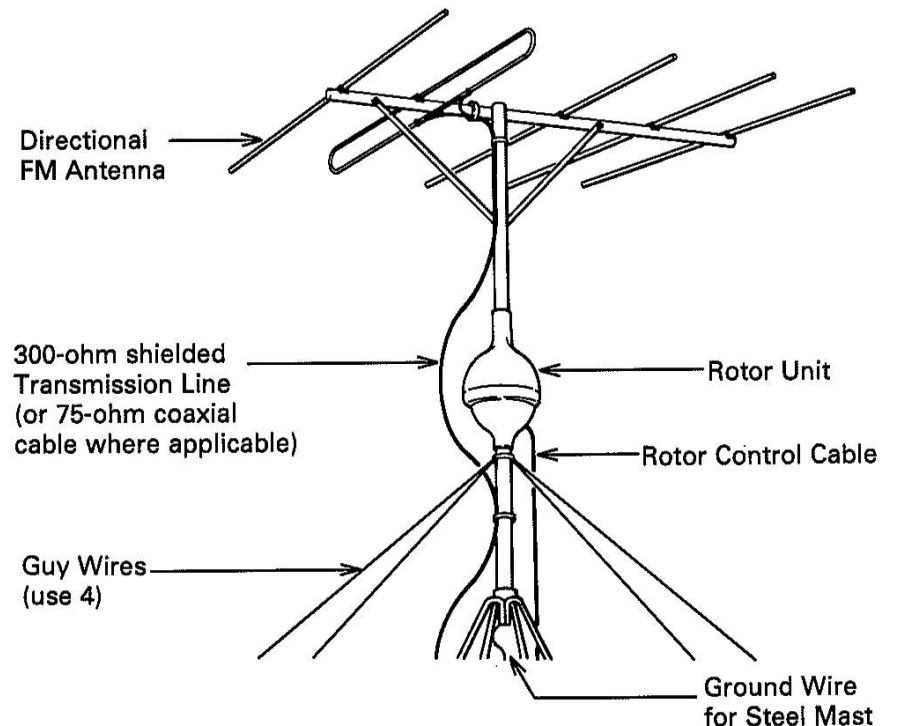

Another important factor is the type of lead-in wire to use. Unshielded lead-in wires, such as 300-ohm twin lead, can act as an omnidirectional antenna, and can cancel the directional benefits of your antenna. Therefore, we recommend using a balanced, shielded 300-ohm cable or a coaxial 75-ohm cable with a 300-to-75 ohm matching transformer at the antenna. These types of shielded cable effectively prevent the lead-in from contributing to multipath distortion.

If you decide to use 75-ohm coaxial cable, we recommend buying cable with "F" type connectors attached. These will fit both the matching transformer and the terminal on the R-113 (See page 10).

It is considered good practice to connect the antenna mast to an earth ground, both for reasons of safety and noise reduction. If 300-ohm shielded cable is used, connect the shield to ground (GND) at the receiver end only (See page 10).

For rural areas, it is recommended to consult a local dealer about installation and lightning arrestor protection.

We don't recommend using master antenna systems, such as those found in apartment buildings. Such systems are usually designed expressly for television reception and frequently suppress or reduce the quality of the FM signals before distribution.

OPERATION GUIDELINES

POWER AND SOURCE SWITCHING

To prevent the possibility of excessive, sudden sound levels, it is recommended that the volume control be placed at a low level position each time the power switch is turned on or when switching between sources.

TAPE RECORDING OPERATIONS

To make a tape recording of any source, proceed as follows:

- (1) Depress the INPUT SELECTOR button for the source you wish to record.
- (2) The source signal will now be fed to the tape deck. Follow the recording instructions for the tape deck in use.
- (3) If you have a 3-head deck, you can monitor the actual recording by depressing the corresponding TAPE-1 or TAPE-2 button on the R-113. The MONITOR position must also be selected on your tape deck.

TAPE PLAYBACK

Playback from either tape deck can be heard by depressing the corresponding TAPE-1 or TAPE-2 button on the R-113.

TAPE DUBBING

Tape copies can be made from TAPE 2 to TAPE 1 as follows:

- (1) Depress both TAPE-1 and TAPE-2 buttons on the R-113.
- (2) Place tape deck 2 in the PLAY mode and deck 1 in the RECORD mode.
- (3) As the recording takes place, the signal that is heard from the R-113 speakers is the output from tape deck 1. Therefore, if deck 1 is a 3-head machine, actual monitoring of the recorded dub can take place.

SIGNAL PROCESSOR JACKS

When using this facility, the following items should be kept in mind:

- (1) The effects of other functions, such as the TONE controls, LOUDNESS, SUBSONIC filter, etc., should always be considered relative to the operation of the external processor.

For instance, "double boosting" effects can occur with a connected equalizer, causing severe overload distortion, if both the equalizer and tone controls are boosted together in the same frequency range.

- (2) When in CD STRAIGHT operation, the SIGNAL PROCESSOR is completely bypassed.

AM/FM TUNER OPERATIONS

The R-113 incorporates several tuning methods to provide easy, yet great flexibility in station selection and use. Proceed as follows:

MANUAL TUNING

- (1) Depress AM or FM input selector button as desired.
- (2) Depress AUTO SEEK button to ensure that AUTO SEEK indicator (item #5) is OFF.
- (3) Depress the up > down < TUNING button as required to tune the desired station.

NOTE: This button can be pressed in one step increments for fine tuning or held down continuously for rapid tuning.

- (4) On FM, when the desired station is tuned, depress the AUTO SEEK button once again for STEREO operation.

OPERATION GUIDELINES

AUTO SEEK TUNING

- (1) Depress AM or FM input selector button as desired.
- (2) Depress AUTO SEEK button to ensure that AUTO SEEK indicator (item #5) is ON.
- (3) Depress the TUNING button in the direction desired to initiate auto seek tuning.
- (4) The receiver will now tune automatically in 10 kHz increments on AM and *200 kHz increments on FM, until a station is found.

NOTE: Due to interfering signals in some areas, it may be found that the tuner will stop at some points off station. If this occurs, simply activate AUTO SEEK again with the TUNING button.

STATION MEMORY OPERATIONS

A total of 20 stations, in any combination of AM and FM stations, and in any random order, may be stored in the receiver's AM/FM RANDOM STATION MEMORY system.

STORE PROCEDURE

- (1) Select AM or FM as desired.
- (2) Tune desired stations using either MANUAL or AUTO SEEK tuning modes.
- (3) Press the 1 — 10/11 — 20 button to choose memory locations 1 through 10 or 11 through 20 as desired.
- (4) Press the STORE button followed immediately by an AM/FM RANDOM STATION MEMORY button of your choice. Repeat for each station, AM or FM that you wish to store.
- (5) Each time STORE is pressed, the MEMO indicator (item #3) will light for 5 seconds or until a MEMORY button is depressed.

- (6) Each time a MEMORY button is depressed, a corresponding memory indicator will light.

- (7) To replace a station already in memory, simply tune the new desired station and repeat the above procedure.

MEMORY SCAN

- (1) When MEMORY SCAN button is depressed, from any tuner mode, each station previously stored in memory will be tuned to automatically for a 5 second interval.
- (2) To cancel, press any tuner function button other than MEMORY SCAN.

STATION RECALL

Stations stored can be played (recalled) instantly by pressing any MEMORY button, selecting locations 1 through 10 and 11 through 20 with the 1 — 10/11 — 20 button.

CARE AND MAINTENANCE

CLEANING

The durable finish of the knobs and heavy aluminum front panel will last indefinitely with proper care and cleaning. Never use scouring pads, steel wool, scouring powders, or harsh chemical agents, such as lye solution. These will mar the finish. Clean with a soft, lint-free cloth or cotton swab slightly dampened with a mild solution of detergent and water.

REPACKING FOR SHIPMENT

Should it become necessary to ship your R-113 for any reason, use the original packing materials. If these are no longer available, be sure that adequate materials, at least equivalent to the original, are used.

REPAIRS

Only the most competent and qualified service technicians should be allowed to service the R-113. The Luxman company and its factory-trained warranty station personnel have the knowledge and special equipment needed for repair and calibration of this precision instrument.

In the event of difficulty, call the toll free telephone number listed on the Warranty to obtain the name and address of the Luxman Authorized Service Station nearest your home or business. In many cases, the dealer where you purchased your Luxman unit will be equipped to provide service.

BLOCK DIAGRAM

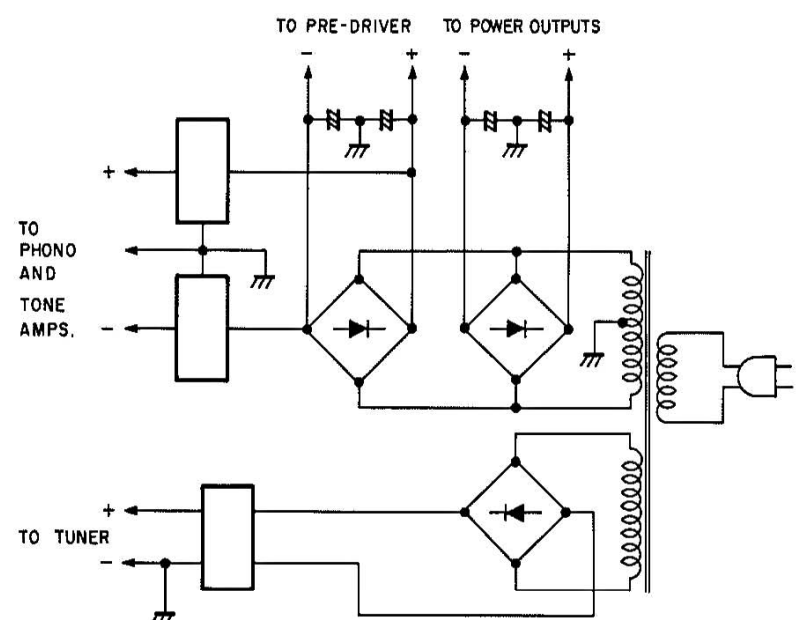
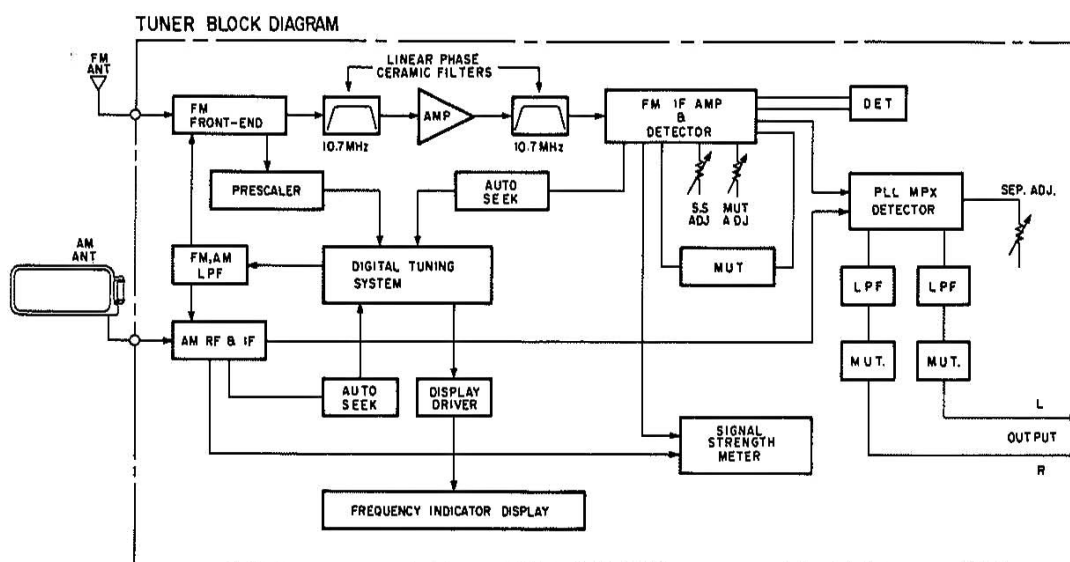
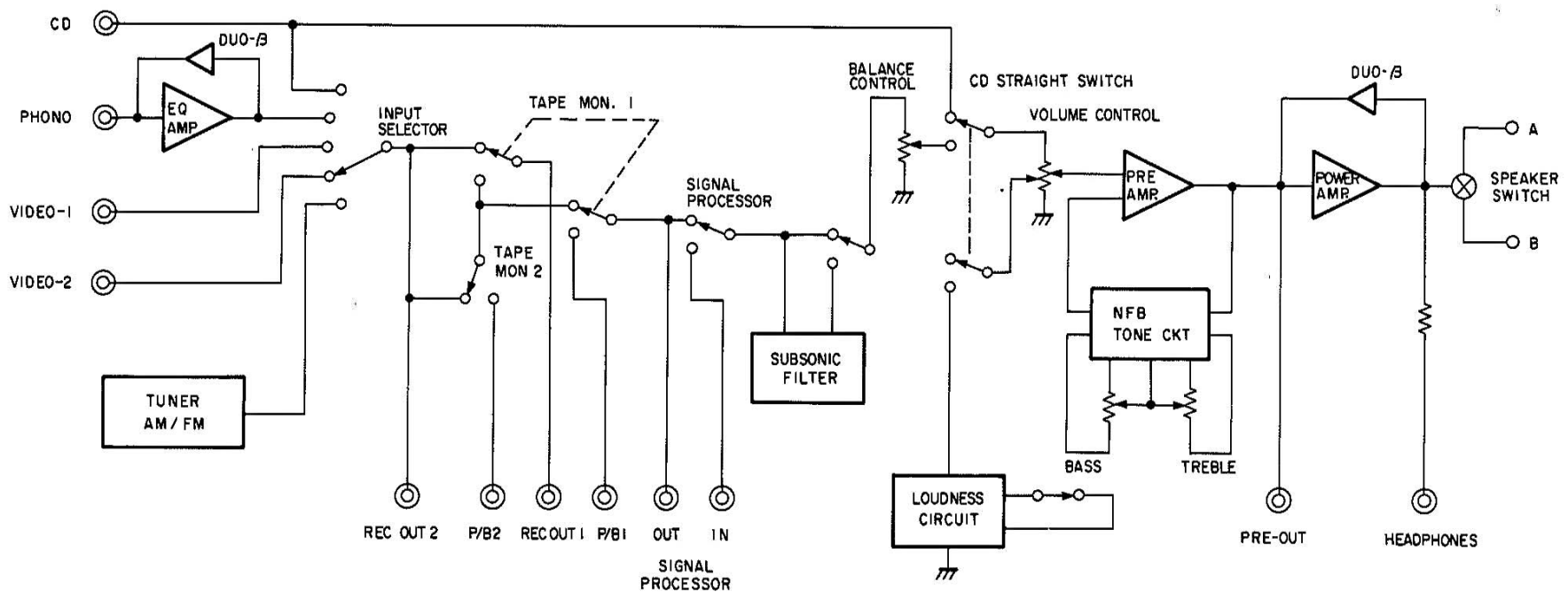

IN CASE OF DIFFICULTY

If you encounter a problem, please review the items in the following checklist. Also, be sure to thoroughly check other connected components, such as speakers, turntable, CD player, cassette deck, equalizer, etc.

PROBLEM	PROBABLE CAUSE AND SOLUTION
Power Does Not Come On.	<ul style="list-style-type: none"> ● Check line cord to ensure good connection at AC outlet.
No Sound.	<ul style="list-style-type: none"> ● Incorrect Input selected. Check input leads on back panel (be sure they match input selected). ● TAPE MONITOR SWITCH IN (without Tape deck connected or TAPE DECK LINE/SOURCE switch in wrong position). ● SIGNAL PROCESSOR switch in (without processor turned on or connected). ● Incorrect SPEAKER switch setting or rear panel SPEAKER LEAD connections. (Check for shorted speaker leads). ● CD STRAIGHT switch on when using a source other than CD. ● Line inputs and outputs of a connected tape deck are reversed.
Distorted Sound. Shuts off at High Volume levels.	<ul style="list-style-type: none"> ● Speaker Impedance too low (less than 2 Ohms). Check speaker specifications. ● Two speaker systems of less than 4 ohms each are in use. Select only one system at a time when playing at high volume levels.
No Sound on Tuner.	<ul style="list-style-type: none"> ● CD STRAIGHT on. Set to OUT (OFF) position. ● FM or AM Antennas not connected or defective cable leads. ● AUTO SEEK MUTING STEREO is on in a weak signal area. Improve antenna and/or place AUTO SEEK in OFF mono mode.
FM Sound Distorted.	<ul style="list-style-type: none"> ● Rotate FM antenna, both indoor and outdoor types for cleanest sound (lowest multi-path interference). ● Use outdoor FM antenna if in weak reception area (see page 12).
AM Reception Poor.	<ul style="list-style-type: none"> ● Rotate AM Loop Antenna on back panel for best pick-up. ● If necessary, remove Loop Antenna from rear mount and try a different location (within limits of 23" lead length). ● Determine if other appliances, TVs, fluorescent lights, CDs, computers, etc. are causing interference.

SPECIFICATIONS

AUDIO SECTION

Power Output	35W x 2 (20 Hz — 20 kHz, 8Ω)
Dynamic Power	84W x 2 (4Ω) 100W x 2 (2Ω)
Total Harmonic Distortion	0.08% 0.025% (1 kHz, 8Ω, 35W)
IM Distortion (SMPTE)	0.03% (8Ω, 35W)
Input Sensitivity/Impedance	
Phono	2.5mV/47KΩ
CD/Tape, AV	150mV/47KΩ
Input Overload:	
Phono	160mV (1 kHz)
Signal-to-Noise Ratio:	
Phono	88 dB (re 5mV input)
CD, Tape, AV	96 dB (re 500mV input)
Frequency Response	
Phono	RIAA, 20 Hz — 20 kHz (±0.5 dB)
CD, Tape, AV	5 Hz — 200 kHz (—3 dB)
Tone Controls, NFB type:	
Bass	±10 dB at 100 Hz
Treble	±10 dB at 10 kHz
Subsonic Filter	
Turnover	18 Hz
Slope	6 dB/octave

FM TUNER SECTION

Tuning Frequency Range	87.9 — 107.9 MHz
Usable Sensitivity (IHF):	
Mono	10.8 dBf
50 dB Quieting Sensitivity:	
Mono	14.0 dBf
Stereo	38.0 dBf
S/N Ratio, IHF "A":	
Mono	78 dB
Stereo	73 dB
Total Harmonic Distortion:	
Mono 1 kHz	0.1%
Stereo 1 kHz	0.15%

Stereo Separation (1kHz)	45 dB
ACS (alternate Chan. Sel., ±400 kHz)	60 dB
Capture Ratio	1.5 dB
Spurious Response Ratio	80 dB
Image Response Ratio (106.1 MHz)	40 dB
AM Suppression	55 dB
IF Response Ratio	60 dB
Frequency Response (30 Hz — 15 kHz)	+0.5 dB, —1.0 dB

AM TUNER SECTION

Tuning Frequency Range	530 kHz — 1,620 kHz
Usable Sensitivity (1000 kHz)	400μV/m
S/N Ratio (1000 kHz)	50 dB
THD (30% Mod.)	0.3%
Selectivity (±10 kHz)	30 dB
Image Response Ratio (1400 kHz)	42 dB
IF Response Ratio (600 kHz)	60 dB

GENERAL

Power Line	
Voltage/Frequency	120V AC/60 Hz*
Consumption	200 Watts
Dimensions	17 1/4" x 4 1/4" x 13 1/2" 438mm x 110mm x 343mm
Weight	
Net	13.5 lbs. (6.1 kg)
Gross	15.9 lbs. (7.2 kg)

* **CAUTION:** Do not use this receiver on 50 Hz power lines.



LUX CORPORATION, JAPAN

1-8, 1-Chome, Nishigotanda, Shinagawa-ku, Tokyo 141, Japan
Phone: 03-493-4381 Facsimile: 03-494-8426

68P81880F54-O
Printed in Japan
Imprimé au Japon
